

STRUCTURAL AND MODAL ANALYSIS IN SOLIDWORKS OF AGRICULTURAL PLOW TO CHOOSE VIBRATION SYSTEM AT MOLDBOARD

Gabriel Gheorghe¹, Daniel Lates², Claudiu Oprea³, Carmen Baltatu¹

¹National Institute of Research-Development for Machines and Installations Designed to Agriculture and Food Industry, Romania; ²IRUM S.A. Reghi, Romania; ³Technical University of Cluj-Napoca, Romania

gabrielvalentinghe@yahoo.com, daniel.lates@irum.ro, claudiu.oprea@emd.utcluj.ro, carmen.vasilachi@gmail.com

Abstract. This article presents the way to obtain the structural model for elementary linear-elastic static analysis of the moldboard of the plow. Also, to prove the functionality of the structural model obtained, the structural analysis results for the linear elastic static test are presented. These results are useful for estimating the safety factor and for assessing the behavior in major overstress situations at the main part of the machine. Structure dynamics is a very broad discipline that uses a huge arsenal of theoretical and experimental methods to solve the fundamental problem of structures: the dynamic response to variable tasks over time. Vibrations, and especially vibration in resonance modes, are problems that occur frequently in large structures. As large structures with large numbers of components cannot be optimally engineered for resonant regimes, it is often done to resolve structures or improve them by using the modal analysis of the mathematical models of these structures. The usefulness of this analysis is particularly evident in the testing phase and even in the first stages of operation when it is necessary to improve the working regime of a product of the type analyzed. The main results of the static linear-elastic structural analysis are the values of the reactions in the holders, vector field distribution of the relative – resultant displacement in the structure, tensor fields' distribution of the specific deformation and the Cauchy stress tensor in the same structure. Also, an important result for structure safety is the distribution of the safety factor. The analysis of the equipment's own spectrum allows proper identification of the main frequencies, at which a resonant working regime can occur as well as the necessary forces to choose the optimal vibration system.

Keywords: vibration, FEM analysis, moldboard, frequencies, blade.

Introduction

The first step is to create a CAD model of the plow in SolidWorks. This model should include all the parts that make up the plow, such as the moldboard, the share, and the shank.

Once the model is complete, the next step is to define the material properties of each part. This includes the Young's modulus, Poisson's ratio, and density. These properties are critical for accurate analysis.

The next step is to apply loads and boundary conditions to the model. This involves defining the forces and moments that act on the plow and how it is constrained. The loads can include the weight of the plow, the force required to pull it through the soil, and the impact of rocks and other obstacles.

With the loads and boundary conditions defined, you can then run a static structural analysis. This analysis calculates the stresses, strains, and displacements of the plow under the applied loads. You can use the results to identify areas of the plow that are likely to experience high stresses and potential failure.

After completing the structural analysis, you can perform a modal analysis. This analysis determines the natural frequencies and modes of vibration of the plow. By knowing the natural frequencies, you can avoid operating the plow at those frequencies to prevent resonance and potential damage.

Once you have identified the natural frequencies, you can then choose the vibration system at the moldboard. The goal is to select a system that operates at a frequency different from the natural frequencies of the plow. This way, the vibration system can effectively break up soil without causing damage to the plow.

In summary, performing a structural and modal analysis in SolidWorks of an agricultural plow can help identify potential failure points and choose an appropriate vibration system at the moldboard. The study of these problems with the help of structural and modal analysis is carried out worldwide [1; 2]. The finite element method is very common in design, because it allows simulation of processes [3-6], stress distribution in the structure [7; 8], assemblies, subassemblies or equipment [8], which are then verified by simulated and accelerated tests [10] to be validated in real conditions.

The resistance encountered [11] by the plowshare during work, in general, can be determined by the relationship:

$$R_{pl} = R_1 + R_2 + R_3, \quad (1)$$

- where R_1 – resistance encountered by the plowshare during its own displacement (in empty space) in the furrow;
 R_2 – resistance encountered by the plowshare during the cutting and deformation of the soil;
 R_3 – resistance encountered by the plowshare during the overturning and lateral displacement of the soil (of the furrows).

After certain substitutions, the final relationship becomes:

$$R_{pl} = kabn_i, \quad (2)$$

- where k – soil resistance during plowing, in $\text{daN}\cdot\text{cm}^{-2}$;
 a – working depth of the plowshare, in cm;
 b – working width of the plow body, in cm;
 n_i – number of plowshares.

The representation of the action of these forces on the plow shaft are shown in Figure 1.

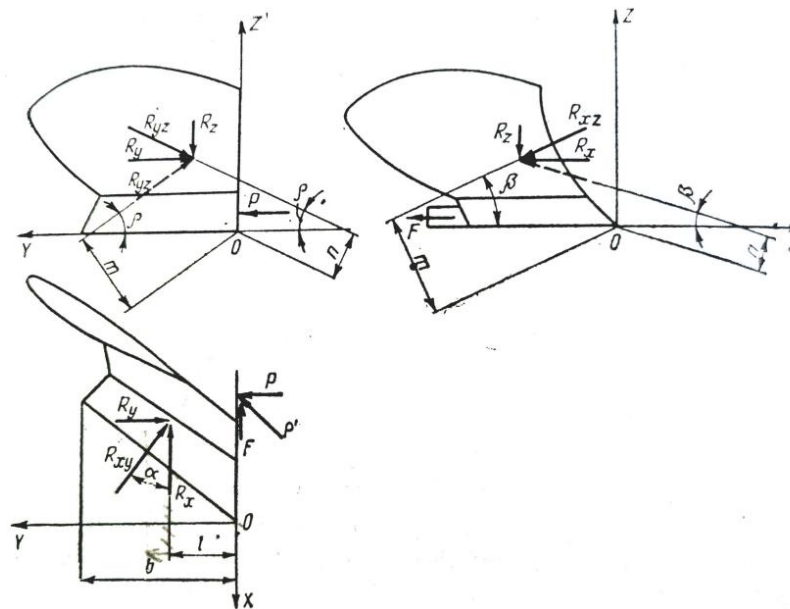

Fig. 1. Action of the forces on the MOLDBOARD from the plow

As results from relation 2, the resistance of the soil to plowing includes all the resistances that oppose the working displacement of the plow. Depending on the type of soil, k has the following values: $0.25\text{-}0.35 \text{ daN}\cdot\text{cm}^{-2}$, for light soils; $0.35\text{-}0.55 \text{ daN}\cdot\text{cm}^{-2}$, for medium soils; $0.6\text{-}0.8 \text{ daN}\cdot\text{cm}^{-2}$, for heavy soils and $0.8\text{-}1.4 \text{ daN}\cdot\text{cm}^{-2}$ for very heavy soils. In our case, ab is the area of the contact surface of the body with the soil, and k is $0.35\text{-}0.55 \text{ daN}\cdot\text{cm}^{-2}$ medium soils.

Overall, the plow is an essential tool for farmers and has been used for centuries to prepare soil for planting crops. Its design has evolved over time to become more efficient and effective, and modern plows can be pulled by animals or machines and come in a variety of sizes and shapes to meet the needs of different farmers and farming conditions.

Materials and methods

The first step in performing the analysis after transforming CAD to CAE format is to establish the input data: the chosen material is E355 with the characteristics from Table 1, calculation of the ab surface for formula (2) in Fig. 2.a, fixing of the body in Fig. 2.b, application of force in Fig. 2.c, and discretization of the structure in Fig. 2.d.

Table 1

Characteristics of material E355

Characteristic	Value	Unit
Elastic Modulus	2.100000031e + 11	N·m ⁻²
Poisson's Ratio	0.28	N·A ⁻¹
Shear Modulus	7.9e + 10	N·m ⁻²
Mass Density	7800	kg·m ⁻³
Tensile Strength	550000000	N·m ⁻²
Compressive Strength		N·m ⁻²
Yield Strength	275000000	N·m ⁻²
Thermal Expansion Coefficient	1.1e-05	K ⁻¹
Thermal Conductivity	14	W·(m·K) ⁻¹
Specific Heat	440	J·(kg·K) ⁻¹

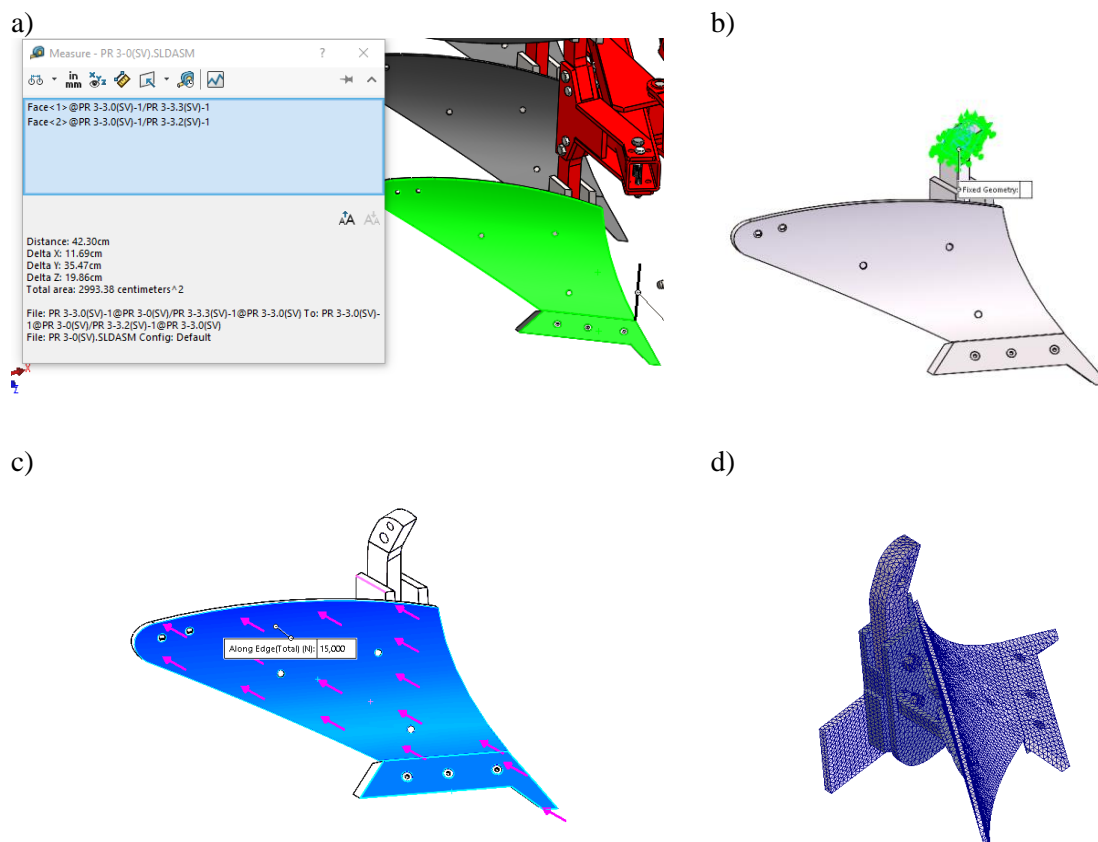

Fig. 2. Input data for Simulation Structural ANALYSIS

Results and discussion

Structural analysis of a MOLDBOARD

The primary outcomes of the linear-elastic static structural analysis include the distribution of the vector field of relative-resultant displacement and Cauchy tension within the structure. Additionally, the safety factor distribution is an essential outcome for ensuring the structure's safety. Figure 3 depicts the distribution maps of the values of the relative displacement field on the structure surface. It is noteworthy that the highest value (approximately 1.29 mm) is situated on the outer edge of the grip region.

Figure 4 displays a colour map of the maximum equivalent tension values, with the area of maximum stress being highlighted. It is important to note that since the analysis is conducted in the

elastic-linear domain, the distribution of the total specific deformation values will coincide with the area of maximum specific deformation.

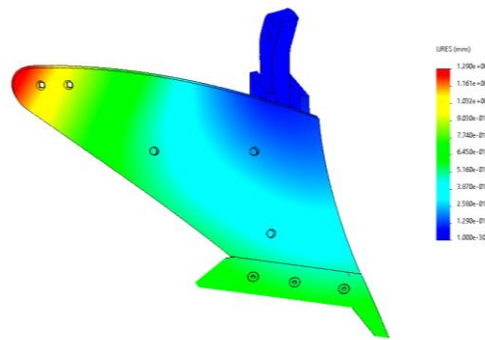

Fig. 3. Distribution of relative displacement field values resulting on the structure surface

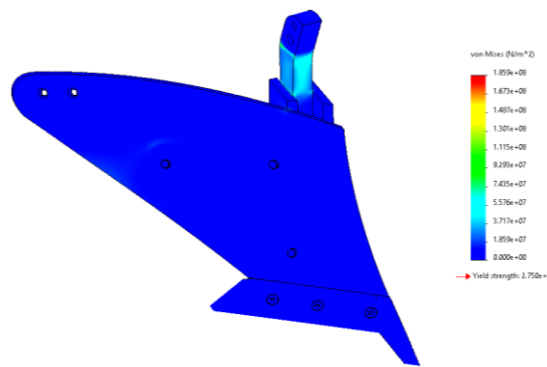

Fig. 4. Representation of equivalent tension distribution on the structure surface

Finally, Figure 5 shows the graphical representation of the safety factor distribution in the structure.

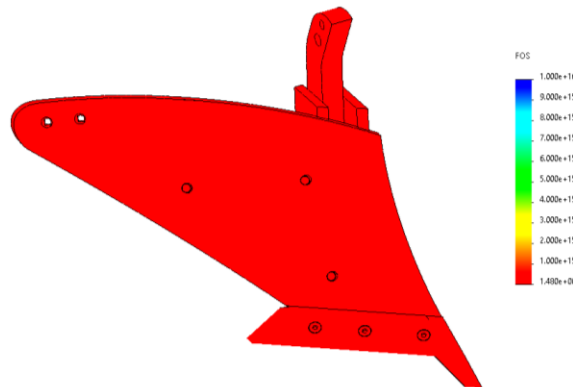

Fig. 5. Safety factor distribution on the structure surface

Modal analysis of a MOLDBOARD

The outcomes of frequency calculation or modal analysis are dependent on a set of frequencies (in Hz) (pulsations in rad/s and periods in s) listed in Table 2 in ascending order, starting from the lowest frequency. The table also displays the relative displacements in each vibration mode separately, including the resultants in the structure. Additionally, colour maps presenting the field of relative displacements on component or resultant are available.

Table 3 shows a list of the first five own frequencies along with normalized displacements on the three directions obtained from the SOLIDWORKS program report using the SIMULATION module for conducting the frequency analysis [12].

Table 2

List of own frequencies of MOLDBOARD

Frequency Number	Rad·s ⁻¹	Hertz	Seconds
1	690.62	109.92	0.0090979
2	695.59	110.71	0.0090328
3	1,637.6	260.63	0.0038369
4	1,852.0	294.75	0.0033927
5	2,280.7	362.98	0.0027550

Table 3

Mass Participation (Normalized)

Mode Number	Frequency (Hertz)	X direction	Y direction	Z direction
1	109.92	0.000801750	0.0100500	0.00085647
2	110.71	0.034532000	0.0025980	0.01407400
3	260.63	0.000027352	0.0119440	0.00048864
4	294.75	0.001314500	0.0068367	0.00100130
5	362.98	0.026875000	0.0408490	0.0133730
Sum		X = 0.063551	Y = 0.072278	Z = 0.029794

An alternative presentation of these findings is demonstrated in Figures 6.a, 6.b, and 6.c, which display the respective own frequencies and the maps of amplitudes on the deformed shape of the structure in vibration modes that correspond to each frequency. Due to space limitations, only three of the five calculated vibration modes are presented in these figures.

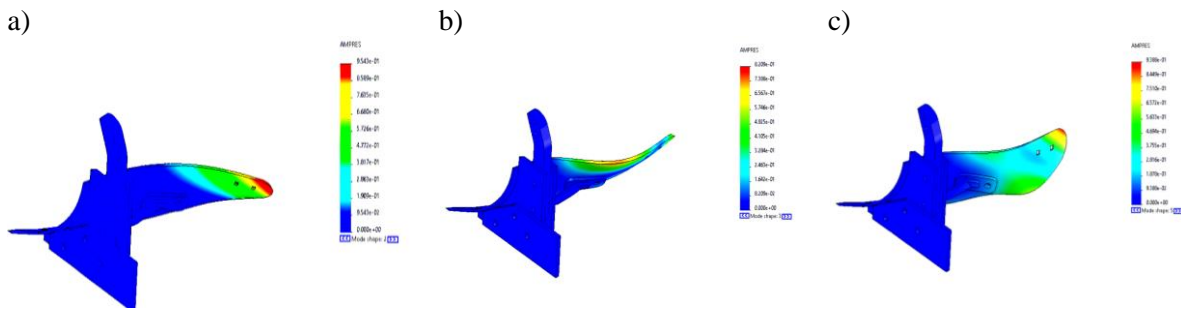

Fig. 6. Maps of amplitudes on the deformed shape of the structure

The chosen vibrating motor has the following characteristics: revolutions 3000 min⁻¹, nominal voltage 24/12 V, unbalance 4 cmkg, centrifugal force 1974 N and a nominal power 0,1kW and positioned on the structure according to Figure 7.

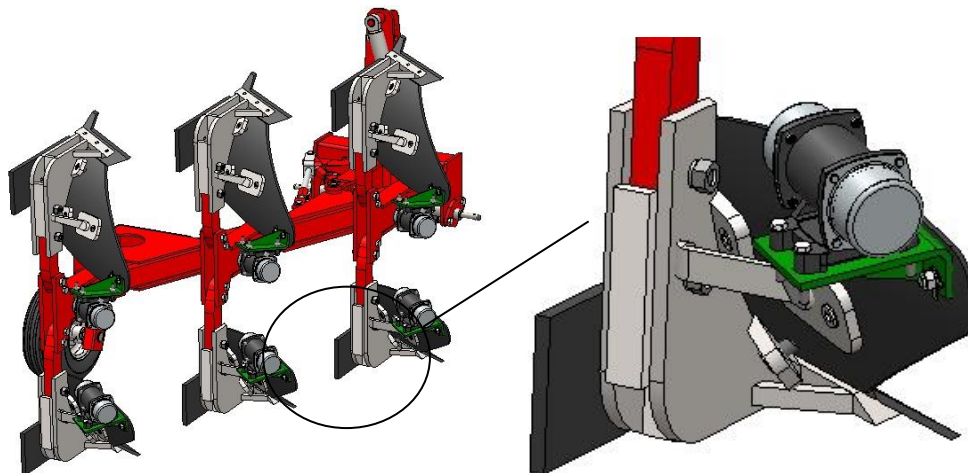

Fig. 7. Positioning the vibrating motor

Conclusions

1. The calculated normal stress, based on the method described in the paper, may overestimate the load capacity of the plow structure if potential accidents occur in the soil (such as hard objects) or if it is used in improper conditions.
2. The safety coefficient value of 1.5, which is commonly used in the design and manufacturing of agricultural machines for soil tillage, suggests that there may be some room for optimization.
3. According to the analysis performed, the frequency of the vibrating motor is below 100 Hz and will not resonate with the structure of the plow.

Acknowledgements

The work was supported by project co-financed from the European Regional Development Fund through the Competitiveness Operational Program 2014-2020, contract No. 1/1.2.1 PTI ap.2/28.12.2022/MySMIS 156531.

Author contributions

Conceptualization, G.G.; methodology, D.L. and G.G.; software, O.C.; Validation, O.C. and G.G.; writing – original draft preparation, G.G.; writing – review and editing, O.C. and D.L.; visualization, D.L., B.C.; project administration, B.C.; funding acquisition, D.L. All authors have read and agreed to the published version of the manuscript.

References

- [1] Nazemosadat S.M.R., Ghanbarian D., Naderi-Boldaji M., Nematollahi M.A., Structural analysis of a mounted moldboard plow using the finiteelement simulation method, *Spanish Journal of Agricultural Research*20 (2), 0204, 14 p. (2022) ISSN: 2171-9292, DOI: 10.5424/sjar/2022202-18157.
- [2] Nejadian H.A., Karparvarfard S.H., Naderi-Boldaji M., Rahmanian-Koushkaki H. Combined finite element and statistical models for predicting force components on a cylindrical mouldboard plough, *Biosystems Engineering*, Volume 186, October 2019, pp. 168-181, DOI: 10.1016/j.biosystemseng.2019.07.007
- [3] Biriş S.Şt., Vlăduţ V. Use of finite element method to determine the influence of land vehicles traffic on artificial soil compaction, *WATER STRESS*, pp. 179-198;
- [4] Biriş S., Maican E., Faur N., Vlăduţ V., Bungescu S. Fem model for appreciation of soil compaction under the action of tractors and agricultural machines, *Proceedings Of The 35 International Symposium On Agricultural Engineering “Actual Tasks on Agricultural Engineering”*, pp. 271-280, 2007, Opatija – Croatia;
- [5] Ungureanu N., Vlăduţ V., Biriş S. FEM modelling of soil behaviour under compressive loads, *International Conference on Applied Sciences (ICAS2016)*, Hunedoara, Romania, 2016, *Materials Science and Engineering*, Vol 163(2017), 012001, pp. 1-9, DOI: 10.1088/1757-899X/163/1/012001;
- [6] Ungureanu N., Vlăduţ V., Biriş S.-Ş., Paraschiv G., Dincă M., Zăbavă B. Ş., Ştefan V., Gheorghişă N. E. FEM modelling of machinery induced compaction for the sustainable use of agricultural sandy soils, *Proceedings Of The 46 International Symposium On Agricultural Engineering “Actual Tasks on Agricultural Engineering”*, pp. 201-211 .
- [7] Biriş S., Maican E., Ungureanu N., Vlăduţ V., Murad E. - Analysis of stress and strain distribution in an agricultural vehicle wheel using finite element method, *PROCEEDINGS OF THE 39 INTERNATIONAL SYMPOSIUM ON AGRICULTURAL ENGINEERING “Actual Tasks on Agricultural Engineering”*, pp. 107-118, 2011, Opatija - Croatia;
- [8] Biriş S., Vlăduţ V., Faur N., Cernescu A., Kabaş O., Matache M., Voicea I., Bungescu S., Popescu C - FEM analysis/testing resistance of a tractor seat, *PROCEEDINGS OF THE 43 INTERNATIONAL SYMPOSIUM ON AGRICULTURAL ENGINEERING “Actual Tasks on Agricultural Engineering”*, pag. 189-200, 2015, Opatija - Croatia
- [9] Vlăduţ D.I., Biriş S., Vlăduţ V., Cujbescu D., Ungureanu N., Găgeanu I. – Verification of stress by FEM analysis-m-1 echanical testing of agricultural mobile aggregates couplig device, *INMATEH – AGRICULTURAL ENGINEERING*, vol. 54, no. 1/2018, pag. 37-46;

- [10] Vlăduț V., Gângu V., Pirnă I., Băjenaru S., Biriș S., Bungescu S. Complex tests of the resistance structures in simulated and accelerated regime on hydropulse installation, Proceedings Of The 35 International Symposium On Agricultural Engineering “Actual Tasks on Agricultural Engineering”, pag 393-404, 2007, ISSN 1333-2651, Opatija – Croația;
- [11] Scriptnic V., Babiciu P., Masini agricole, Editura Ceres, Bucuresti, 1979.
- [12] Gabriel Valentin Gheorghe, Catalin Persu, Iuliana Gageanu, Dan Cujbescu, Structural and modal analysis in solidworks of basic structure of equipment to prepare germinative bed in strips, Volume 17, 17th International Scientific Conference Engineering for Rural Development Proceedings, 2018, pp. 818-826.